

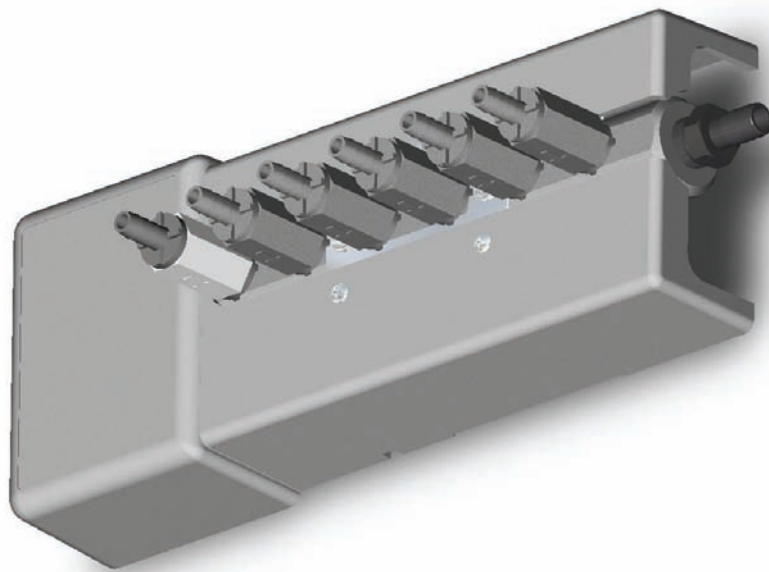

NOVA CONTROLS
LEADING THE WAY
A **Hydro** Systems Company

Crescent Flush Manifold

FOR LIQUID LAUNDRY SUPPLY SYSTEMS



Reference Manual

FM-300 Series

1 Description

Overview

The FM-300 series Flush Manifold is intended for use with our Nova Controls laundry dispensing systems. The FM-300 series Flush Manifold is a single unit that includes the water valve, manifold, and flow switch all in one convenient assembly. This manifold is designed to provide the easiest and most cost effective means of flushing liquid laundry products when used with a Nova Controls laundry dispensing system.

Theory of Operation

The FM-300 series Flush Manifold transfers liquid laundry chemical products from the dispensing system to the washer using water flow (or flush) via a single discharge tube. The dispenser pumps into the manifold via the check valves. The flush valve controls water flow through the manifold, which in turn transfers product to the washer. The flush valve may be controlled by our Eclipse or Orion 2 Dispenser Controllers.

Specifications

Table 1 FM-300 Series Flush Manifold Specifications

Maximum Discharge Tube Length	50 feet
Minimum Input Water Pressure	12 psi
Maximum Input Water Pressure	15 psi
Minimum Water Flow Rate	0.65 gpm
Minimum Input Water Temperature	50° f
Maximum Input Water Temperature	120° f

* Specifications subject to change without notice.

System Diagram

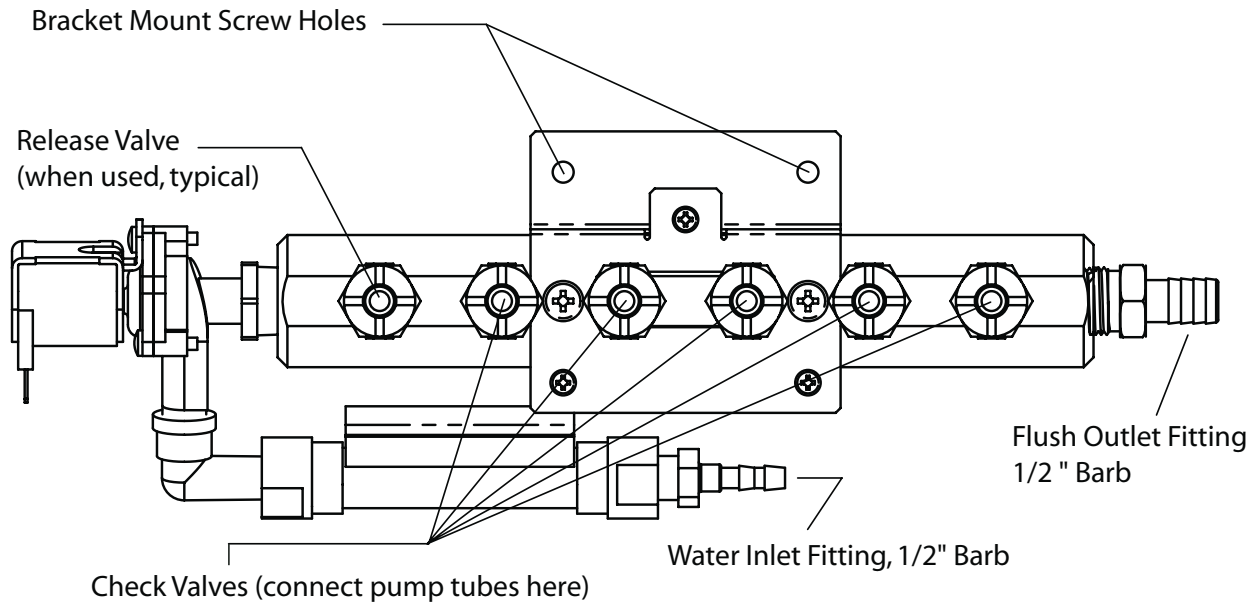

Figure 1 Top-Down View, FM-300 Flush Manifold System Diagram

Pumpstand with Manifold

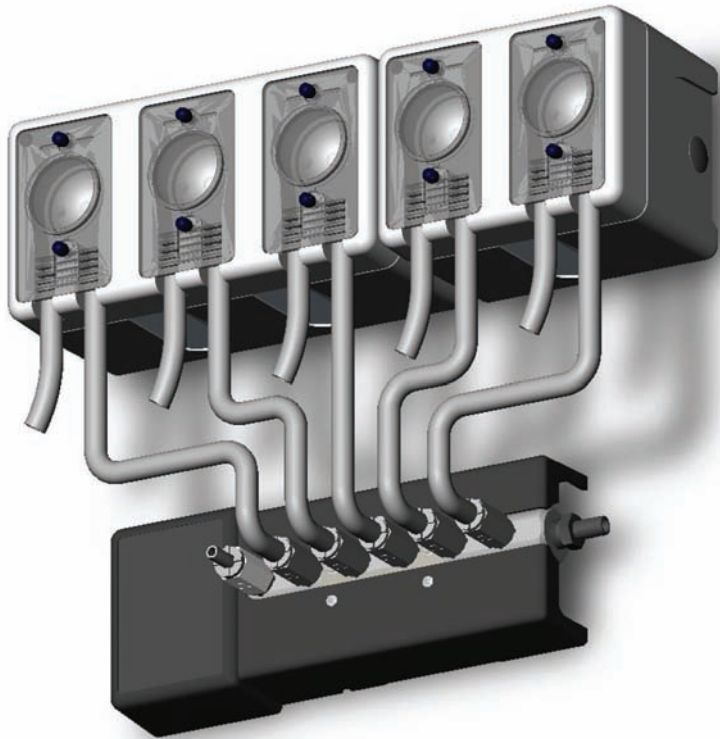



Figure 2 Wall Mounted FM-300 Flush Manifold with Eclipse LM-250 Pumpstand

2 Installation

Overview

The FM-300 is designed to be installed directly underneath the Nova Controls laundry dispensing system Pumpstand. The FM-300 can be either attached to the wall or mounted directly onto the pumpstand with the optional mounting bracket. Electrical installation simply requires connecting a plug connector to the underside of the Nova Controls laundry pumpstand.

<p>ADDITIONAL REQUIREMENTS</p> 	<p>A locally approved back-flow prevention device—not provided—is required for safe and legal operation.</p> <p>A water pressure regulator is required to limit flow pressure to the flush manifold to 12-15 psi at flow (.65 gpm minimum flow rate). This regulator may be shared by a number of flush manifolds.</p> <p>It is important that the flush discharge hose DOES NOT exceed 50'.</p>
---	--

Mechanical Installation

1. Install FM-300 on the pumpstand bracket and secure with supplied hardware.
2. Connect water inlet and flush outlet hoses.

Optional Wall Mounting

1. Remove cover to access mounting bracket.
2. Position the FM-300 on the wall below the dispenser pumpstand with the water inlet and flush discharge fittings on desired end.
3. Using a pencil, outline each of the two mounting holes on the FM-300 mounting bracket.
4. Drill outlined holes with a 1/4" masonry bit and place a wall anchor, supplied, into each hole.
5. Secure the manifold assembly to the wall anchors with supplied screws.
6. Replace the cover.
7. Drop strainer into hose connection and connect hose to spigot.
8. Connect flush outlet hoses.

<p>Note</p> 	<p>Water inlet fitting size is 1/4" barb fitting (1/2" ID hose). To connect other size/type water inlet and/or flush outlet hoses, obtain fittings locally.</p>
--	---

Pump Tube Connection

Use short lengths of 3/8" ID tubing and appropriate size (3/8" x 3/8" or 1/4" x 3/8") hose barbs (supplied with installation kit) to connect discharge side of dispenser pumps to Check Valve hose barbs.

1. Connect lengths of the 3/8" ID flexible tubing that are long enough to connect the dispenser pump tubes with the corresponding check valves on the flush manifold.
2. Secure the flexible tubing to the pump tube barbed fitting with hose clamps or tie wraps to ensure a leak-free assembly.
3. Trim the 3/8" ID tubes to fit—do not connect to the check valves yet.
4. Perform "Calibrate Pumps" on the controller, capturing product at open ends of flexible tubing.
5. Connect flexible tubing to the hose barbs on the check valves. Secure with hose clamps or tie wraps to ensure a leak-free assembly.

Hard Copper Plumbing

- If the water supply connection must be copper tubing, you must obtain the correct pipe fittings and connectors to complete the installation locally.
- Always use an approved Back Flow Prevention Device and Water Pressure Regulator.
- Hose barb fittings can be removed and replaced with the appropriate fittings to accommodate copper tubing.
- Use RTV sealant on the plastic plumbing threads and DO NOT solder to fittings that are threaded into plastic.

Electrical Connection

The FM-300 series flush manifold has a single electrical connector specifically designed to connect to the Nova Controls Laundry series pumpstands.

Caution 	DO NOT connect any voltage other than 24 VAC to the solenoid coil! For applications that only have a higher voltage available, you must use a step-down transformer to drop the flush output voltage to 24 VAC.
---	---

1. Depress locking tab on Nova Controls laundry dispenser shorting connector (connected to flush connector on non-flush units) and remove.
Retain for reuse in case the pumpstand is used without flush in the future!
2. Connect the FM-300 connector to the pumpstand flush connector.

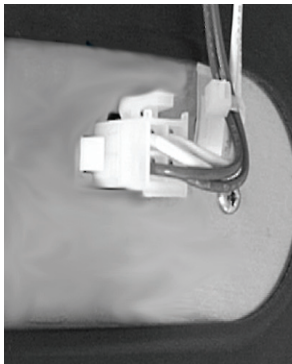

Figure 3 Pumpstand Flush Connector

3

System Setup

Testing System Operation

After installation, check entire dispensing system for correct electrical and plumbing connections.

1. After pump calibration and formula programming, test run the system to determine appropriate flush time setting to transfer all product to the washer. Input this flush time in Program Mode of the controller.
2. Reconfirm that the washer calls for product at appropriate times and the dispensing system pumps when it should. Flush manifold water inlet pressures should be measured while flushing. Adjust the water pressure regulator for an inlet pressure of 12-15 psi (.65 gpm minimum flow).
3. Inspect flush system for water leaks, and test run a load of linen.

Opening Flush Valve Manually

To manually open flush valve in order to purge or clean water lines and manifold, use the Prime Pumps function of the Eclipse or Orion 2 Controllers. If no product delivery is required, use an unused pump position or temporarily remove the pump tube while doing this.

This page intentionally left blank.

4 Spare Parts

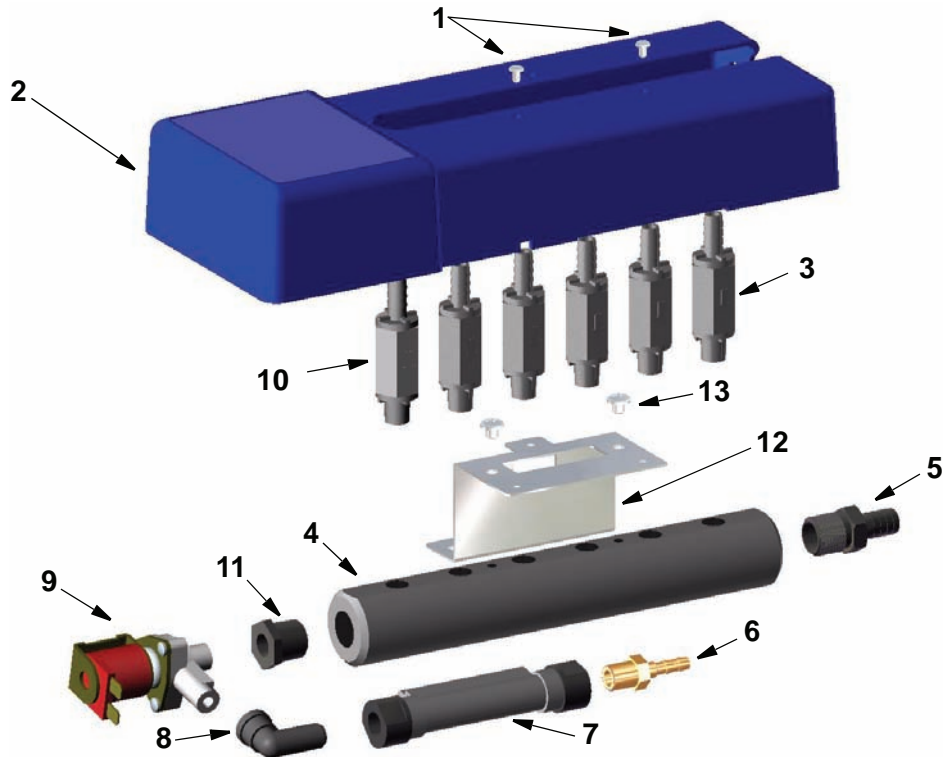

Table 1 Spare Parts Listing

Ref. #	Description	Part Number
1	Cover Screws	30-03123-0806A
2	Cover	27-06926-10
3	Check Valve 3/8" Barb	41-04207-46
4	Manifold, blank, no parts	46-07525-02
5	Outlet Fitting	41-04996-01
6	Inlet Fitting, 1/4" MPT x 1/4" Barb	41-06473-44
	Inlet Fitting, 1/4" MPT x 3/8" Barb	41-06473-46
	Inlet Fitting, 1/4" MPT x 1/2" Barb	41-06473-84
	Inlet Fitting, 1/4" MPT x 1/4" Tube	41-07017-44
7	Flow Switch Kit, includes fittings and wiring harness	13-06592-00
8	Elbow, 1/4" FPT	41-06924-44
9	Solenoid Valve, 24 VAC Coil (coil not replaceable)(no strainer)	49-06472-10
10	Release Valve, 1/3 psi	41-04807-00
11	Reducer Bushing	41-03965-072
12	Mounting Bracket	23-07754-00
13	Bracket Screws	30-03123-2504
*	Strainer Kit (with washer), 70 mesh, 10 pk.	13-08480-10

Limited Warranty

SELLER warrants solely to BUYER the Products will be free from defects in material and workmanship under normal use and service for a period of one year from the date of completion of manufacture. This limited warranty does not apply to (a) hoses; (b) and products that have a normal life shorter than one year; or (c) failure in performance or damage caused by chemicals, abrasive materials, corrosion, lightning, improper voltage supply, physical abuse, mishandling or misapplication. In the event the Products are altered or repaired by BUYER without SELLER'S prior written approval, all warranties will be void.

NO OTHER WARRANTY, ORAL, EXPRESS OR IMPLIED, INCLUDING ANY WARRANTY OF MERCHANTABILITY OR FITNESS FOR ANY PARTICULAR PURPOSE, IS MADE FOR THESE PRODUCTS, AND ALL OTHER WARRANTIES ARE HEREBY EXPRESSLY EXCLUDED.

SELLER'S sole obligation under this warranty will be, at SELLER'S option, to repair or replace F.O.B. SELLER'S facility in Watsonville, California any Products found to be other than as warranted.

Limitation of Liability

SELLER'S WARRANTY OBLIGATIONS AND BUYERS REMEDIES ARE SOLELY AND EXCLUSIVELY AS STATED HEREIN. SELLER SHALL HAVE NO OTHER LIABILITY, DIRECT OR INDIRECT, OF ANY KIND, INCLUDING LIABILITY FOR SPECIAL, INCIDENTAL, OR CONSEQUENTIAL DAMAGES OR FOR ANY OTHER CLAIMS FOR DAMAGE OR LOSS RESULTING FROM ANY CAUSE WHATSOEVER, WHETHER BASED ON NEGLIGENCE, STRICT LIABILITY, BREACH OF CONTRACT OR BREACH OF WARRANTY.

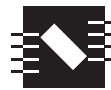

NOVA CONTROLS
LEADING THE WAY

A Hydro Systems Company

225 WESTRIDGE DRIVE
WATSONVILLE, CALIFORNIA
95076-4168 U.S.A.

N. AMERICA 800.252.6682
WORLDWIDE 1.831.786.1470
FAX 1.831.786.1650